

FIRE PUMPS

Selecting the equipment to cover the fire risk

Maximum protection from the destructive hazards of fire demands the utmost in reliability and performance from fire fighting equipment. These prime qualities are built into every Thompsons Kelly & Lewis Fire Pump, regardless of its size and application.

TKL Fire Pumps are the end product of more than 100 years of specialised engineering and design experience in the centrifugal pump field – experience which ensures a completely dependable source of fire protection for industrial and commercial applications.

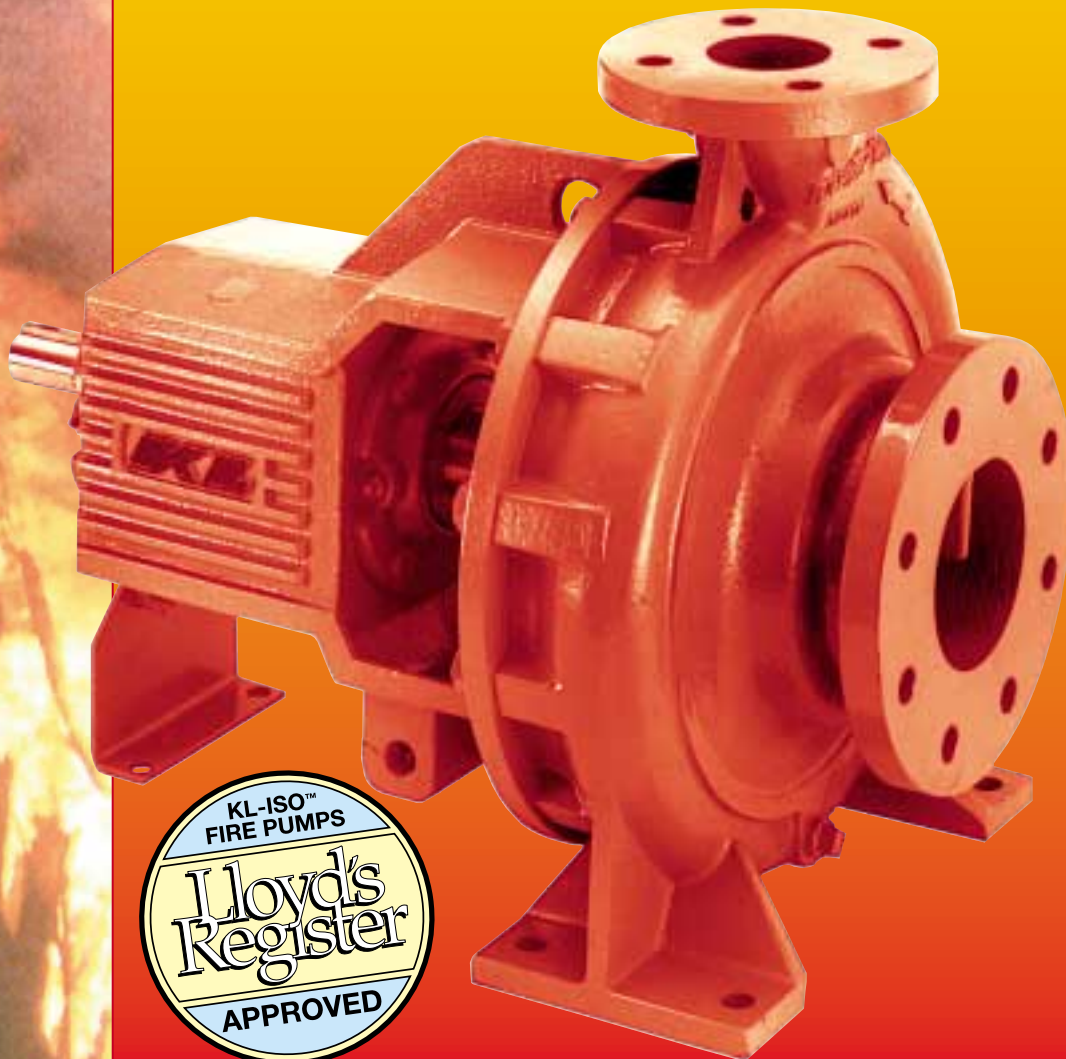

Thompsons Kelly & Lewis

The fire stops here



KL-ISO™

BACK PULL-OUT FIRE PUMP

Thompsons Kelly & Lewis offers a complete range of KL-ISO Fire Pumps for the vital role of protecting life and property in Australia and overseas.

Construction

The horizontal KL-ISO Fire Pump is the usual preference of owners, consultants, architects and engineers.

All KL-ISO Fire Pumps are specifically designed and ruggedly constructed to meet the requirements of the Fire Protection Industry.

To ensure total reliability, TKL Fire Pumps conform to the highest quality standards and comply to many Fire Codes and Standards.

Design

KL-ISO Fire Pumps are manufactured to ISO2858 Standard. Pump materials are available to suit water conditions. The KL-ISO Fire Pump, when built-up into a pumpset including drivers and controllers, is capable of operating in any climatic condition.

Mounting

Any type of approved pumpset mounting arrangement can be accommodated, including horizontal fixed, transportable skid baseplates and trailer types to suit customer requirements.

Types of Drive

Electric motor and diesel drive.

Auxiliary Equipment

A complete and reliable fire protection system includes fittings and accessories in addition to the Fire Pump. Most auxiliary equipment is available commercially and can be supplied to comply with local codes and regulations.

Service

Recognising that a product is only as good as the service it receives, TKL provides an immediate response service to resolve customer site problems quickly.

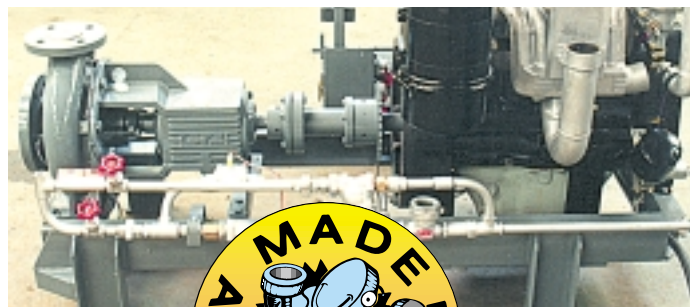
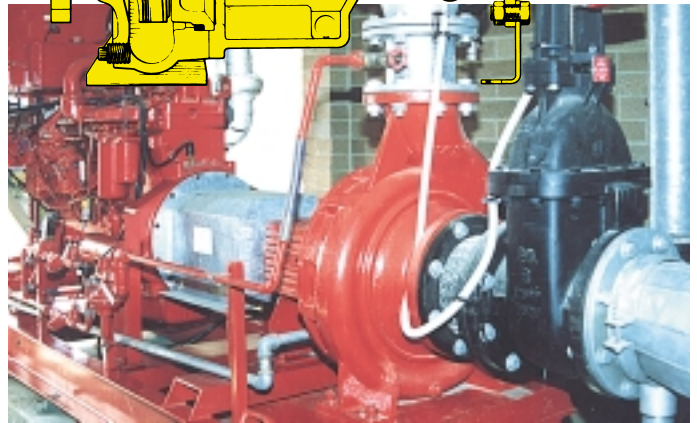
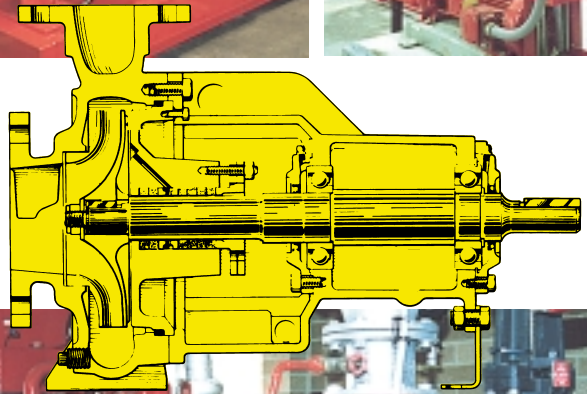
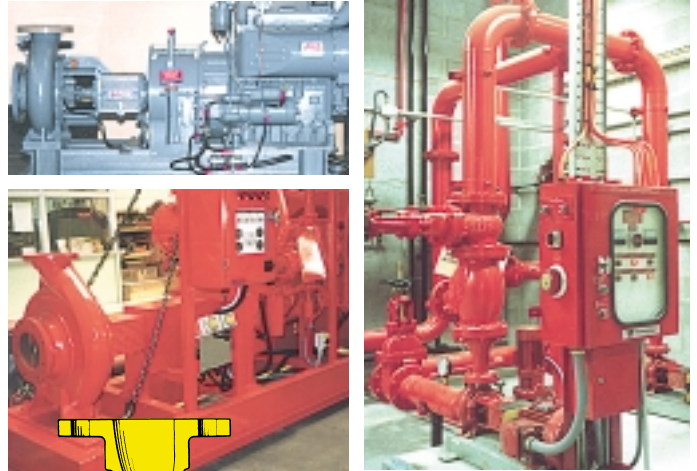

Thompsons, Kelly & Lewis Pty. Ltd.
A.B.N. 15 004 249 012
26 Faigh Street Mulgrave Victoria 3170 Australia
PO Box 160 Springvale Victoria 3171 Australia
Tel +61 3 9562 0744 Fax +61 3 9562 2816
E-mail: tkl.sales@tkl.com.au
Internet: www.tkl.com.au

For further information, sales, service or technical assistance, consult your telephone directory for nearest sales office.
AUSTRALIA Sydney Melbourne Brisbane Adelaide Perth
NEW ZEALAND Christchurch Hamilton
EAST ASIA Singapore
TM - Trademark owned by Thompsons, Kelly & Lewis Pty Ltd
Alteration Rights Reserved



Quality
Endorsed
Company
ISO 9001 Lic 2685
Standards Australia