

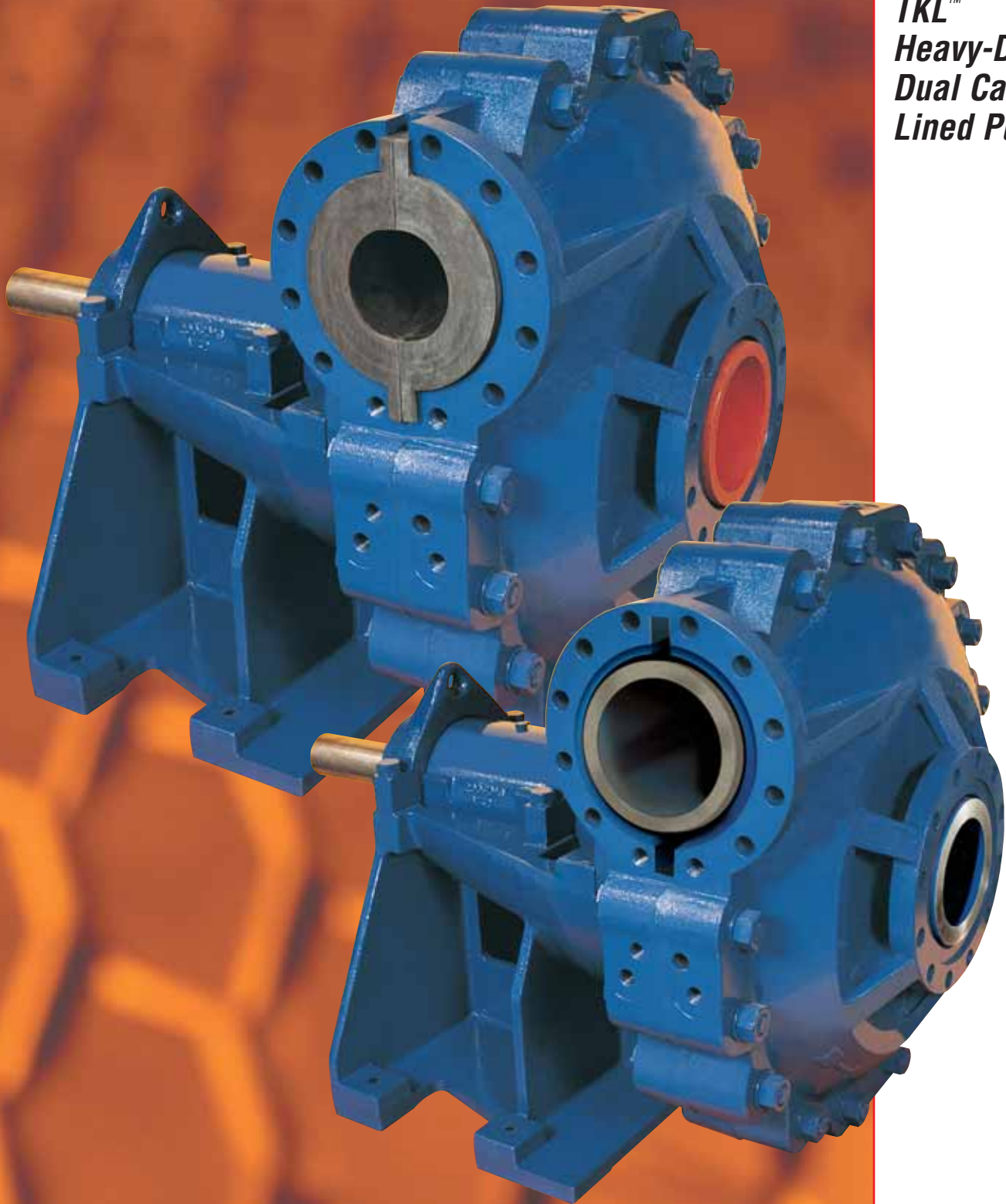

Pump Division



Titan™ Slurry

***TKL™
Heavy-Duty,
Dual Case
Lined Pump***

Pump Supplier To The World

Flowserve is the driving force in the global industrial pump marketplace. No other pump company in the world has the depth or breadth of expertise in the successful application of pre-engineered, engineered and special purpose pumps and systems.

Pumping Solutions

Flowserve is providing pumping solutions which permit customers to continuously improve productivity, profitability and pumping system reliability.

Market Focused Customer Support

Product and industry specialists develop effective proposals and solutions directed toward market and customer preferences. They offer technical advice and assistance throughout each stage of the product life cycle, beginning with the inquiry.



Dynamic Technologies

Flowserve is without peer in the development and application of pump technology, including:

- Hydraulic engineering
- Mechanical design
- Materials science
- Intelligent pumping
- Manufacturing technology

Broad Product Lines

Flowserve offers a wide range of complementary pump types, from pre-engineered process pumps, to highly engineered and special purpose pumps and systems. Pumps are built to recognized global standards and customer specifications.

Pump designs include:

- Single stage process
- Between bearing single stage
- Between bearing multistage
- Vertical
- Submersible motor
- Rotary
- Reciprocating
- Nuclear
- Specialty

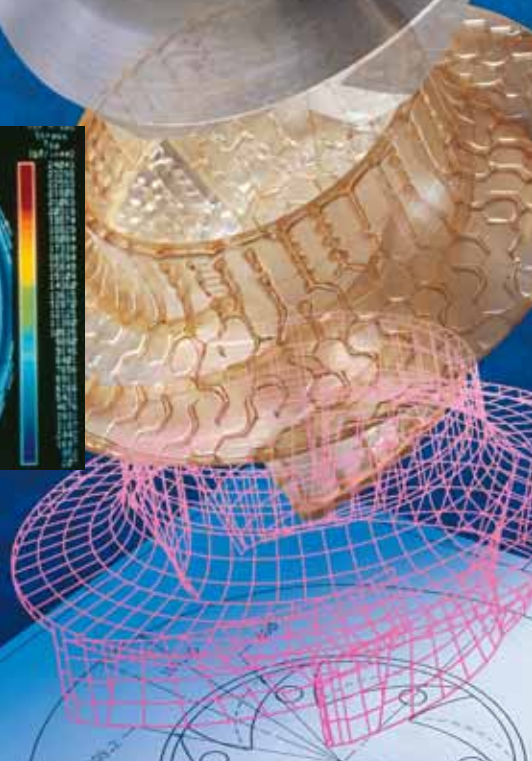
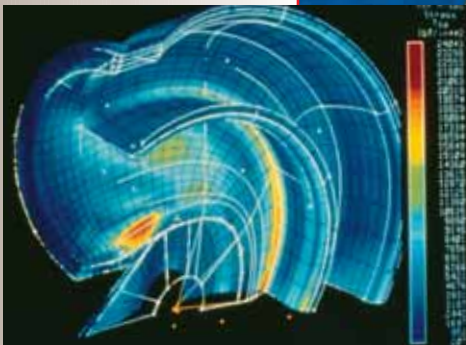

***Titan Slurry
Heavy-Duty,
Dual Case
Lined Pump***

Heavy-Duty Construction

The Flowserve TKL Titan Slurry pump is a true mill-circuit slurry pump. It reflects the company's innovation and engineering expertise in hydraulic design, materials science and manufacturing excellence. Moreover, the Flowserve TKL Titan Slurry pump is a proven design from a company with more than a century of experience in mining's toughest applications.

Materials Interchangeability of Wear Components

The Titan Slurry's dual casing design permits interchangeability of the wear components to enhance the pump's versatility, whether the application demands elastomeric or hard metal materials of construction. Wear components can easily be converted from elastomeric to hard metal and vice versa. This flexibility translates into reduced inventory requirements and reduced operating costs.

Applications

- Abrasive process slurries
- Tailings – high and low pressure
- Sand and gravel
- Bottom and fly ash
- Dredging
- Quarry duties
- Cement production
- Alumina production
- Mine dewatering
- Mill discharge and scale
- Cyclone feed
- Flotation transfer
- Thickener feed
- Lime circulation
- Sugar processing

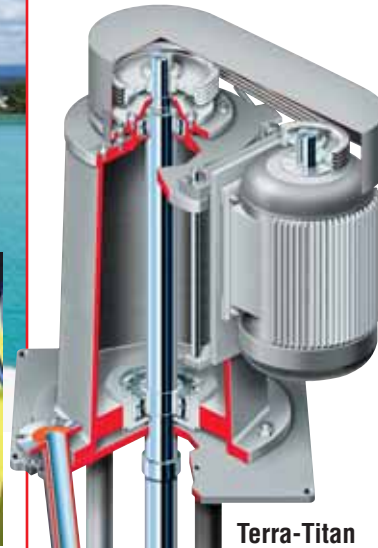

Terra-Titan

Complementary Pump Designs

- Type R rubber lined slurry pump
- Type M hard metal slurry pump
- LC chemical slurry pump
- Types MJ and MJC vertical hard metal slurry pumps
- Types RJ and RJC vertical rubber lined slurry pumps
- Terra-Titan vertical sump pump

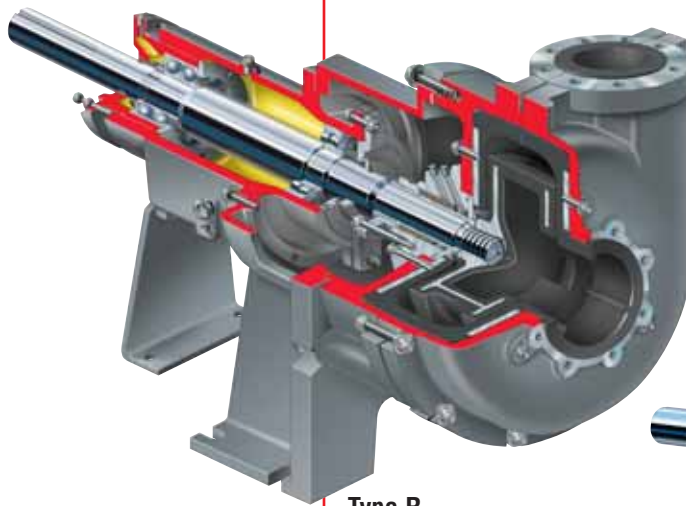

Type R

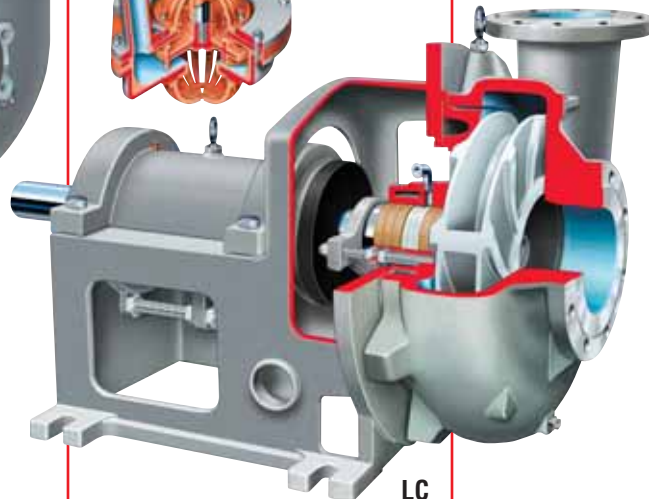

LC

***Titan Slurry
Heavy-Duty,
Dual Case
Lined Pump***

The Flowserve TKL Titan Slurry pump is a horizontal, single stage, end suction configuration with a dual case and a tangential discharge. It is engineered to handle high concentrations of coarse, abrasive solids in suspension. The Titan Slurry's

unique dual case is designed to use either a hard metal or elastomeric liner for application flexibility.

The heavy-duty Titan Slurry can be bolted in place of similar dual casing design slurry pumps with little or no site modification. Its superior hydraulic design results in the industry's highest efficiencies.

Operating Parameters

- Flows to 3600 m³/h (16 000 US gpm)
- Heads to 90 m (300 ft)
- Temperatures to 110°C (230°F)
- Pressures to 25 bar (360 psi) standard; 40 bar (580 psi) high pressure
- Sizes 50 to 350 mm (2 to 14 in)

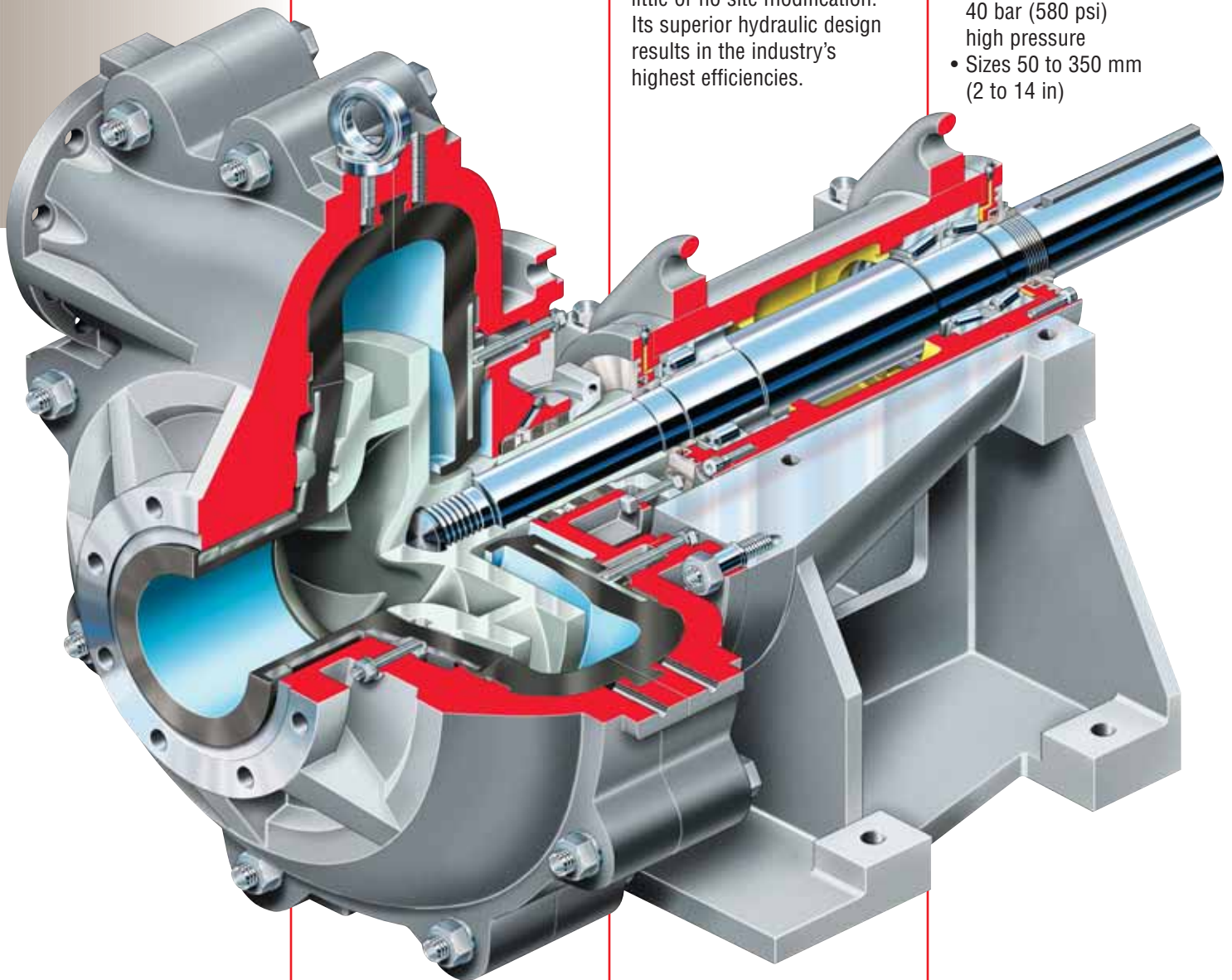

Dual Casing provides access to elastomeric or hard metal liners for inspection or replacement. Machined mating faces provide proper liner compression. Both the radial joint and piping connections are complete through-bolt designs for ease of disassembly

Elastomeric and Hard Metal Liners are fully interchangeable, allowing the most economical material to be used

High Efficiency, Closed Vane Impeller has adjustable face clearance and generous wear allowance. Threaded shaft to impeller design eliminates troublesome impeller nut

Removable Stuffing Box converts to various shaft sealing options without modification to the shaft, liner or impeller. Choice of materials available for corrosive applications

Bearing Cartridge incorporates back-to-back taper roller bearings to carry axial and belt loads. A roller bearing supports the impeller radial loads. Most models utilize double seal barrier, labyrinths and contact lip seals to maintain a clean environment for longer service life

The bearing cartridge can be removed from the pump frame for service exchange or workshop overhaul

Rugged Full Frame Support provides secure mounting for reduced vibration while allowing for casing rotation. Cradle mount of cartridge permits its easy removal without disturbing alignment and with minimal dismantling. Impeller axial adjustment is external of the cartridge

Significant Benefits

- Heavy-Duty Reliability
 - Extra thick wear allowances
 - Oversized shaft and bearings
 - Improved NPSHR for wider application
 - Less cavitation and impeller wear
 - Maximum wet-end life between rebuilds
- Reduced Costs
 - Optimal hydraulic selection
 - Lower energy costs
 - Reduced pump and parts inventory requirements
 - Higher peak efficiency values
 - Reduced maintenance costs
 - Increased uptime
- Versatility
 - Multiple configurations
 - Choice of materials to suit application
 - Parts interchangeability

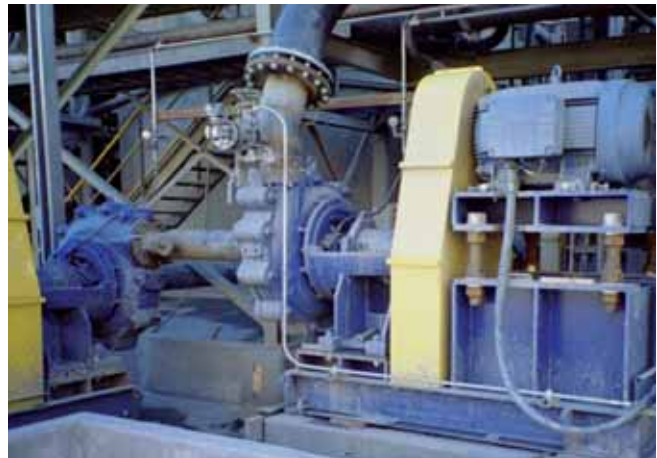

Easily Retrofittable

The Titan Slurry conforms to industry standard slurry pump dimensions. All base mounting holes, flange sizes and positions are dimensionally compatible with the industry's most widely used pumps. This enables the Titan Slurry to be installed in place of competitor pumps with little or no site modification.

Multiple Materials

The Titan Slurry offers liner components in numerous materials of construction to maximize wear resistance.

- Natural rubber and polyurethane are suitable for fine solids and mildly corrosive slurries
- High chrome iron is preferred for applications containing coarse solids, as well as those at higher pressures and temperatures
- Ceramic materials exhibit outstanding abrasion and corrosion resistance. They are recommended for hot, corrosive slurries

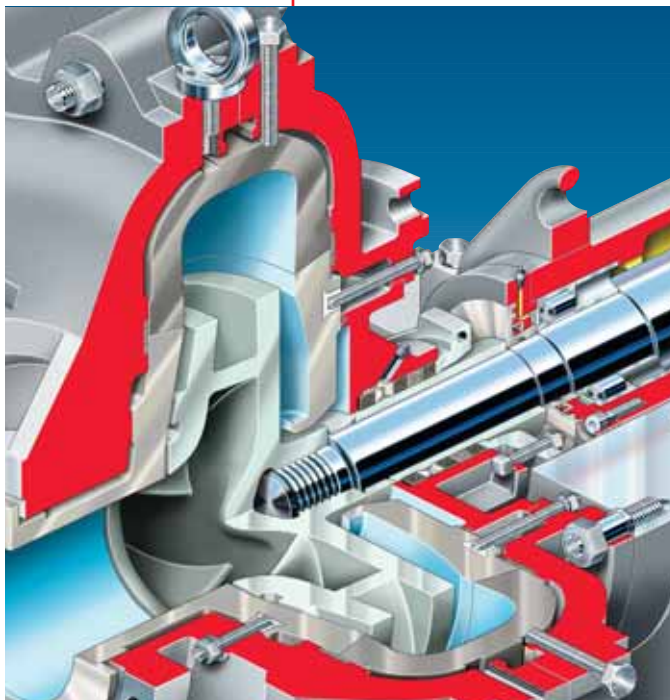

Captive Metal Liners are safely handled during in situ rebuilds. The volute is removed while positively clamped into the casing by clamp bolts. Eyebolt meets all lifting safety regulations

Innovative Lined Dual Case Design

The Titan Slurry boasts state-of-the-art hydraulic design to withstand the demands of severe slurry applications. The dual case design employs an innovative, replaceable liner system to maximize wear resistance, efficiency and pump life while minimizing total cost of ownership.

Metallic volute liners are accurately aligned with dual adjustment fasteners through the outer casing. Elastomeric volute liners are secured to the casing halves with dovetail fits.

Front and back liners are positively located through the casing with studs.



Options and Technical Data

Available Options

- Mill duty impellers
- Sugar industry suitable open type impeller
- High pressure casings for series pumping

Drive Options

- Direct coupled
 - Direct drive base mounted
- Belt driven
 - Side drive base mounted
 - Direct overhead motor mount
 - Reverse overhead motor mount

Shaft Sealing Methods



Removable Stuffing Box permits easy seal maintenance or seal conversion

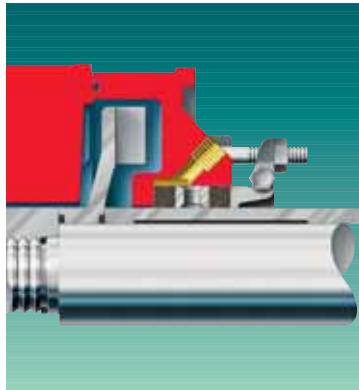

Optional Expeller Seal uses centrifugal force to expel fluid from the seal chamber. Recommended for applications in which abrasive particles cause frequent packing failures, clean water is limited, or product dilution is not tolerable.

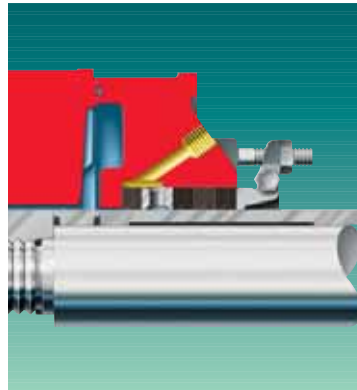

Gland Packing is available for most applications. Extra deep stuffing box accepts high quality gland packing, lantern ring and split gland. Recommended for mineral processing applications in which clean water is available and pump operates in a controlled environment.

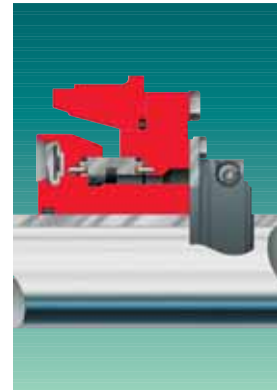

Mechanical Sealing is available for *no leak* applications and to meet environmental requirements. Most quality mechanical seals such as the Flowserve SLC and SLM types can be fitted as required.

Titan Slurry Range Chart

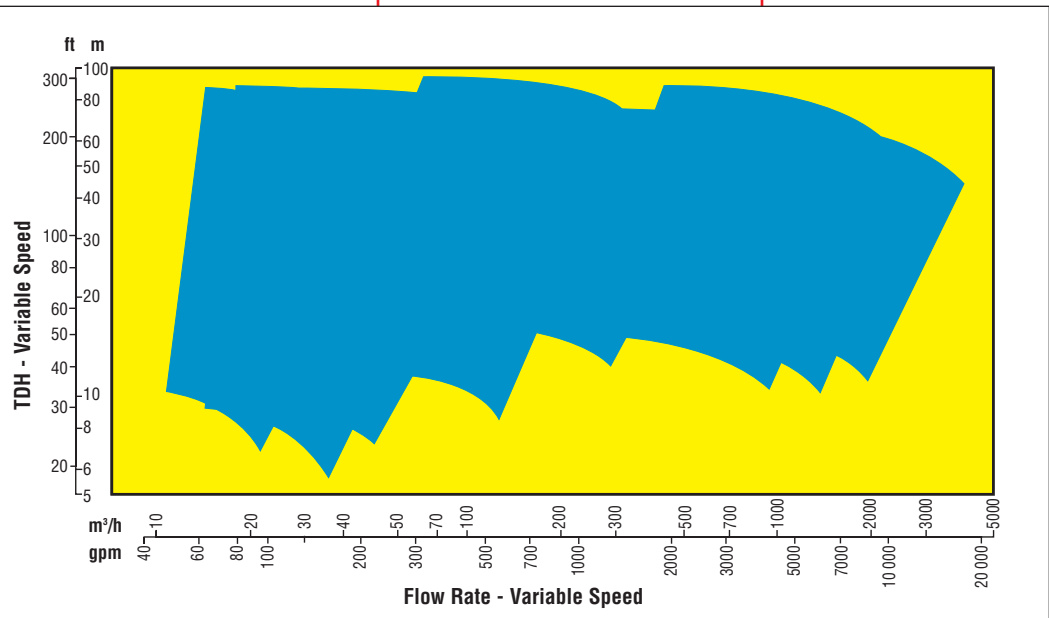

Global Engineered Services and Support

- Total Cost Reduction*
- Asset Management*
- Product Life Cycle*
- Performance Re-rates*
- Site Diagnostics*
- Repair Services*
- Energy Management*
- Spare Parts*
- Maintenance Contracts*
- Materials Upgrades*
- Turnkey Services*
- Field Repairs*
- Installation*
- Project Supervision*
- Commissioning*
- Equipment Upgrades*
- Condition Monitoring*
- Systems Analysis*
- Field Machining*

Service Dedication

Flowserve Engineered Services is focused on providing customers with uncompromising service and support, where and when needed. Dedicated to delivering the highest quality support, Engineered Services integrates its extensive pump and materials engineering knowledge with creative service solutions. Engineered Services fully understands the business challenges facing customers and is prepared to manage solutions to succeed as a team.

A worldwide network of service and repair centers staffed by highly skilled engineers and technicians is available around the clock, seven days a week to respond to customer queries, to evaluate and troubleshoot problems and to provide reliable solutions.



Strength of Experience, Commitment to Excellence

Flowserve has long served industries requiring superior equipment performance and service life.

- Oil and gas production
- Hydrocarbon processing
- Chemical processing
- Water resources
- Power generation
- Nuclear
- Mining and mineral processing
- Pulp and paper
- General industry

Engineered Services is dedicated to maximizing equipment performance and providing reliability-centered maintenance programs for pumps and related equipment, regardless of manufacturer. Using the FlowStar™ asset management software, Engineered Services tracks performance and supports improvement programs using a service life cycle cost business approach. The results are improved reliability and increased profitability.

Business Partner

Flowserve partners with customers to respond to the dynamic business conditions that affect them. Flowserve will work with customers to drive efficiency, maximize throughput and control process quality. Whether user needs involve on-site technical assistance or broader project planning with full turnkey responsibility, Flowserve Engineered Services will deliver professional, reliable results.

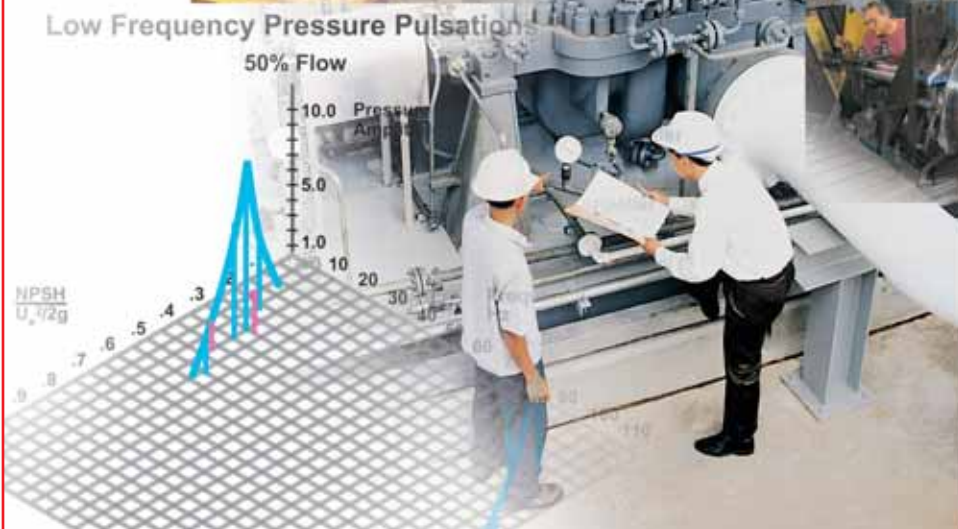

**Flowserve... Supporting Our Customers
With The World's Leading
Pump Brands**



USA and Canada

Flowserve Corporation
Pump Division
5215 North O'Connor Blvd.
Suite 2300
Irving, Texas 75039-5421 USA
Telephone: 1 972 443 6500
Telefax: 1 972 443 6800

Europe, Middle East, Africa

Worthington S.P.A.
Flowserve Corporation
Via Rossini 90/92
20033 Desio (Milan), Italy
Telephone: 39 0362 6121
Telefax: 39 0362 303396



Pump Division

Your local Flowserve representative:

**To find your local Flowserve representative
please use the Sales Support Locator System
found at www.flowserve.com**

Or call toll free: 1 800 728 PUMP

Latin America and Caribbean

Flowserve Corporation
Pump Division
6840 Wynnwood Lane
Houston, Texas 77008 USA
Telephone: 1 713 803 4434
Telefax: 1 713 803 4497

Asia Pacific

Flowserve Pte. Ltd.
Pump Division
200 Pandan Loop #06-03/04
Pantech 21
Singapore 128388
Telephone: 65 6775 3003
Telefax: 65 6779 4607